

Conference Phone/Conference Microphone User Manual

PARTS LIST

Conference Phone

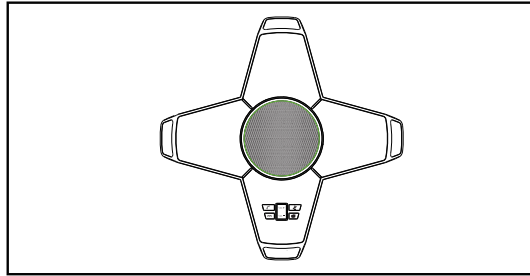

Parts List

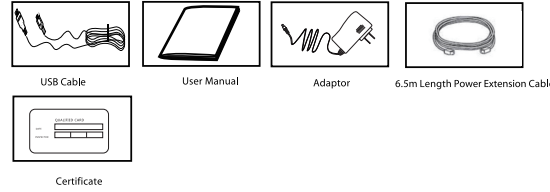

Optional Accessories

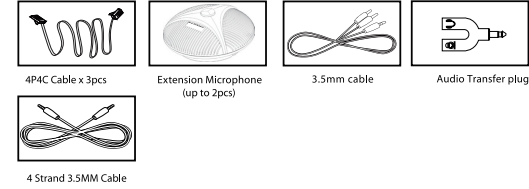

If any items are missing or damaged, contact your place of purchase immediately. Do not use damaged products!

INSTALLATION AND PRECAUTIONS

For best performance of the device, please do not use it in the following kinds of locations:

- Areas with high background noise. The microphone(s) might pick up these sounds and prevent the speakerphone from going into receiving mode when finish talking.
- Place where the phone would be subject to vibrational forces.
- Uneven surface. Do not install or place it in a corner, under a cupboard, or next to a cabinet. These locations may cause an echo effect.
- Do not place any objects within 60cm from this device.

Caution:

To reduce the risk of personal injury, fire, or damaged, use the recommended power adaptor only.

Installing

1. If you need USB call, connect one end of USB cable into USB port of the conference, the other end into a PC or Video system.
2. If you need call by mobile phone, connect the earphone of mobile to "IN/OUT" port of conference phone by 4 Strand 3.5mm Cable.
3. When selecting two extension microphones, plug the optional extension microphones into EXT1 and EXT2 jacks of the conference phone. This function is available for the conference phone model. When installing 2 extension microphones, use 4P4C cable to connect the phone and the 4P4C plug of the extension microphones.
4. If you need to get external amplifier connected, please plug one end of the 4 strand 3.5mm cable into "AUX" port of conference phone, and the other end into the input port of amplifier (Only for USB Connection).
5. Conference phone can support USB power supply, after USB connection with a PC or Video system, the conference phone will be into working status.
6. Conference phone power can also be supplied by an adaptor. If necessary, please plug the DC plug of the adaptor into the Power Jack of the conference phone, then plug the other end of the adaptor into a standard AC power outlet.

2208A4V1.0

Connection Diagram

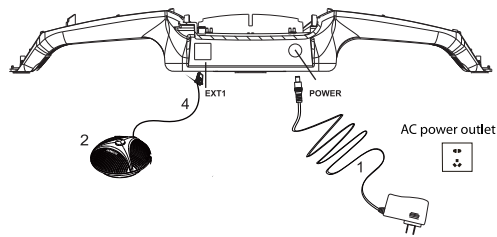

1. Power Adaptor
2. Extension Microphone 1 (optional)

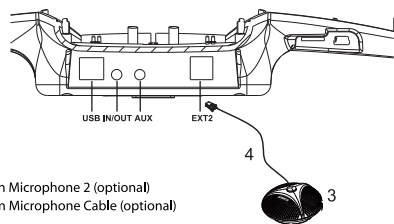

3. Extension Microphone 2 (optional)
4. Extension Microphone Cable (optional)

Interface Introductions:

- POWER: Power jack on the port bay of the conference phone.
 EXT1: EXT1 jack of extension microphone
 EXT2: EXT2 jack of extension microphone
 USB: Connect to PC, or video system.
 AUX: Audio jack connect to external audio device
 IN/OUT: Connect to LINE IN/OUT device, or mobile phone

Self-Detecting:

When the conference phone has access to electricity, the self-detecting program will be activated.

- Red light, blue light and green light flash alternatively three times

GETTING TO KNOW YOUR PHONE

Parts of the Phone

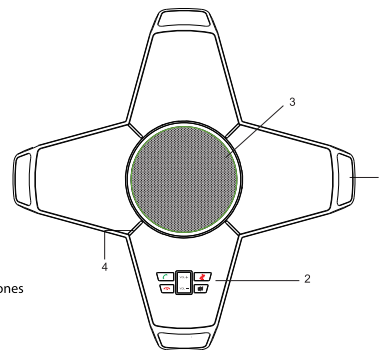

1. Microphones
2. Keypad
3. Speaker
4. LED

Keypad

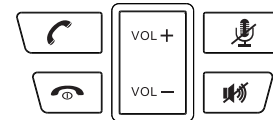

	Off hook key	Lync off hook
	Hang up key	Lync hang up
	Microphone mute key	Mute microphone
	Speaker mute key	Mute speaker
	Volume up key	Adjust volume up
	Volume down key	Adjust volume down
	PC Mode	Press "Mute" key for two seconds till blue LED indicators will turn on, then press "Mute" key and green LED indicators will flash 3 times. "PC MODE" is activated successfully.
	Mobile Mode	Press "Mute" key for two seconds till blue LED indicators will turn on, then press "Mute" key and green LED indicators will flash 3 times. "MOBILE MODE" is activated successfully.

If not expected key is pressed during blue LED indicators on, the blue indicators will be off, and mode setting will be terminated

LED Indicators

- Blue: USB / Mobile Phone is connected
- Red: Microphone mute
- Blinking blue: Speaker mute
- Blinking green: PC Mode and Mobile Mode switching is undergoing.

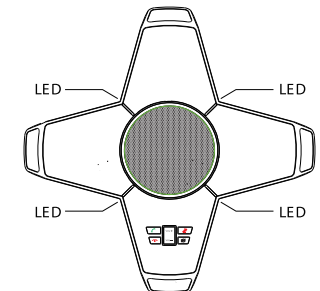

Placing a VoIP Call in USB Mode

Support to connect to PC and video conferencing system via USB, providing up to 48 KHz bandwidth for speaker and microphones. Make sure the PC/ video devices are ready when placing a call.



Connection Steps for USB

1. Connect one end of USB cable into PC or video system, the other end into of conference phone USB port.
2. It will takes few seconds to install the driver automatically for the first setup.
3. The blue LEDs keep on then the conference phone gets into USB mode.
4. Open the softphone platform you select, such as video conference system, video conference software, UC, and other instant communication softwares.

Useful settings for PC and Video Teleconferencing System.

Increase or decrease the volume of speaker and microphone to get the best voice quality for other video teleconferencing system.

Do not activate the automatic gain control (AGC) effect of speaker and microphone.

Do not activate the sound processing effect (such as automatic gain control(AGC), echo cancellation(AEC) and noise suppression(NSI) of software on the PC or video system .

Use HD voice codec if possible.

Placing a Softphone Call via LINE IN/OUT

Method 1

1. Connect the microphone and speaker port of audio transfer plug to PC or video conferencing system with 3.5mm cable.
2. Insert audio transfer plug into the "IN/OUT" port of conference phone.
3. Please set the LINE IN/OUT mode to "PC Mode"

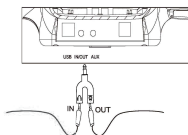

Method 2

1. Connect the "IN/OUT" port of conference phone to the Microphone port of PC or video conferencing system with 3.5mm cable.
2. Please set the LINE IN/OUT mode to "PC Mode"

- ✎ If connect to headset port of laptop or desktop computer - microphone port of video conferencing system, then LINE IN/OUT need switch to "Mobile Mode"

Placing a call via Mobile Phone

- ✎ This feature allows you to take advantage of the conference phone speaker and For example, if you were in call on your mobile phone, you could connect your mobile phone to continue your conversation and microphones to continue your conversation and include everyone in the room in the conversation.

For these instructions, it is assumed that the mobile phone is turned on, the mobile phone is on conversation, and the conference phone is connected to the mobile phone via the 3.5mm 4 strand cable.

Connection Steps for Mobile Phone

1. Connect the "IN/OUT" port of to conference phone the earphone port of mobile phone with 3.5mm cable.
2. Please set the LINE IN/OUT mode to "Mobile Mode".

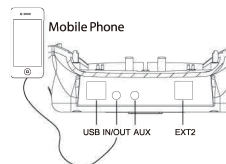

Connection Steps for External Amplifier

1. Insert the USB plug into the USB port of conference phone.
2. Connect the AUX port to the input port of amplifier.
3. Connect complete, switch on external amplifier.

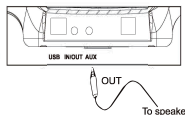

- ✎ It's recommended to mute the inner speaker but keep the inner microphones on. (Press 'Speaker mute key' to mute the speaker)

- ✎ This feature is working only at USB connection

Multi-party Conference Call & Line Mode Selection conference phone allows you to hold conference calls via analog LINE IN/OUT (or mobile phone), USB VOIP simultaneously. All above network will be mixed automatically. You can add another line or switch between connected lines during a call freely.

conference phone supports plug and play for the above kinds of lines conveniently. It is no need to undertake any settings, anytime and anyway.

INSTALLING EXTENSION MICROPHONE

For an important meetings or a large meeting, please use extension microphones.

1. Plug the optional For an important meetings or a large meeting, please use extension microphones. extension microphone into the EXT1 and EXT2 jacks of the Conference phone.
2. Plug the DC plug of the adaptor into the POWER jack of the conference phone then plug the other end of the adaptor into a standard AC power outlet.
3. The microphone will pick up well if you are facing it. The inner microphone position is shown as in the figure below.
4. There are MUTE button and status LED on the extension microphone.
 - ✎ Green LED indicate that microphone is on work.
 - ✎ Red LED indicate that microphone is muted

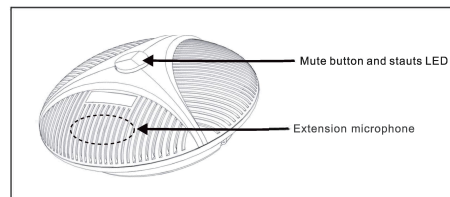

NOTE:

You should plug and pull the cable to extension microphone's 4P4C jacks while power supply is disconnected to ensure microphone work well.

When using your telephone equipment, basic safety precautions should always be followed to reduce the risk of fire, electric shock and injury to persons, including the following:

- This unit is NOT waterproof! DO NOT expose this unit to moisture.
- DO NOT expose this unit to rain.
- Do not use this product near water, for example, near a bath tub, wash bowl, kitchen sink or laundry tub, in a wet basement or near a swimming pool.
- Avoid using a telephone (other than a cordless type) during an electrical storm. There may be a remote risk of electric shock from lightning.
- Do not use the telephone to report a gas leak in the vicinity of the leak.
- Use only the power cord indicated in this manual.

SAVE THESE INSTRUCTIONS!

Important Notice:

Under power failure conditions this appliance may not operate. Please ensure that a separate telephone, not dependent on local power, is available for emergency use.

ONE-YEAR LIMITED WARRANTY

IMPORTANT Satisfactory evidence of the original purchase is required for warranty service

Please refer to our website ***** for any details or warranty durations offered in addition to those contained below.

Terms of Warranty

***** warrants to the original retail purchaser only that the Conference Phone ("the Product"), will be free from defects in materials and craftsmanship for the duration of the warranty period, subject to the limitations and exclusions set out below.

Warranty Period

This warranty to the original retail purchaser expire one (1) year from the date of the original retail sale.

If a warranty claim is made, this warranty will not apply if the Product is found by ***** to be:

- (A) Damaged or not maintained in a reasonable manner or as recommended in the relevant ***** Owner's Manual;
- (B) Modified, altered or used as part of any conversion kits, subassemblies or any configurations not sold by *****. Improperly installed contrary to instructions contained in the relevant Owner's Manual;
- (C) Repaired by someone other than an authorized ***** Repair Agent in relation to a defect or malfunction covered by this warranty;
- (D) Used in conjunction with any equipment, parts or a system not manufactured by *****

Parts Covered

This warranty covers the Product and included accessories.

User-generated Data

This warranty does not cover any claimed loss of or damage to user-generated data (including but without limitation phone numbers, addresses and images) that may be stored on your Product.

Statement of Remedy

If the Product is found not to conform to this warranty as stated above, the Warrantor, at its discretion, will either repair the defect or replace the Product without any charge for parts or service. This warranty does not include any reimbursement or payment of any consequential damages claimed to arise from a Product's failure to comply with the warranty.

Our goods come with guarantees that cannot be excluded under the local Consumer Law. You are entitled to a replacement or refund for a major failure and for compensation for any other reasonably foreseeable loss or damage. You are also entitled to have the goods repaired or replaced if the goods fail to be of acceptable quality and the failure does not amount to a major failure.

Procedure for Obtaining Warranty Service

Depending on the country in which the Product was first purchased, if you believe that your Product does not conform with this warranty, you should deliver the Product, together with satisfactory evidence of your original purchase (such as a legible copy of the sales docket) to ***** at the addresses shown below. You should contact ***** regarding any compensation that may be payable for your expenses incurred in making a warranty claim. Prior to delivery, we recommend that you make a backup copy of any phone numbers, images or other data stored on your Product, in case it is lost or damaged during warranty service.